

Advantages of the Prorunner PR12

- Extremely high positioning accuracy (servomotor)
- Robust column ladder design allows lifting of heavy loads
- Fully standardized, user friendly modular design
- High quality constructive finishing
- Top global brands standard components used
- Heavy duty option for weights up to 300 kg
- Suitable for AGV / AMR thanks to positioning accuracy
- Low maintenance requirements
- Available with independently driven 1 or 2 carriers
- Capable of handling pallet sized products

| Specifications | Qimarox - Prorunner PR12 | AGV/AMR | STANDARD | HEAVY DUTY |
|---------------------|--------------------------|---------|----------|------------|
| Max. load capacity | kg | 160 | 200 | 300 |
| Max. speed | m/s | 2 | 2 | 1,2 |
| Height bottom level | mm | 200 | 194 | 194 |
| Height top level* | mm | 23.327* | 23.399* | 23.149* |
| Conveyor length | mm | 1050 | 1125 | 1450 • |
| Conveyor width | mm | 800 | 760 | 1200 • |

• Larger product sizes needs to be reviewed by engineering
 • Preliminary value
 * Maximum lift height



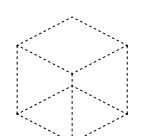

Maximum product size
-
850 x 700 mm •

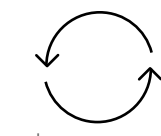

Maximum speed
-
2 m/s

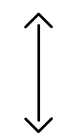

Maximum height
-
up 24 m

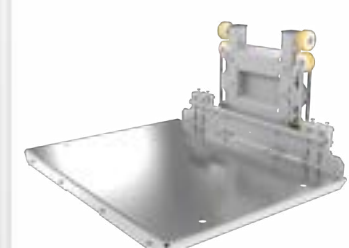

Single carrier
-
1,2 m²

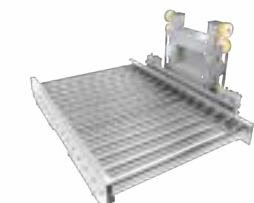

Double carrier
-
2,1 m²

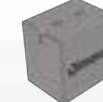
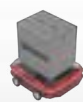

Key Components for material handling:

- Vertical Conveyors
- Palletizing Modules
- Sorting & Buffering
- Pallet Stackers
- Safety Fencing

Key Components for material handling:

- Vertical Conveyors
- Palletizing Modules
- Sorting & Buffering
- Pallet Stackers
- Safety Fencing