

**PRORUNNER MK5-XL
VERTICAL CONVEYOR**

Customer: _____

E-mail: _____

Product: _____

Product sizes: min. x x mm.
max. x x mm.

Capacity: min. p/min. max. p/min.

Product weight: min. kg. max. kg.

Product orientation infeed: Short / Long Side Leading

Product orientation outfeed: Short / Long Side Leading

Product infeed height: mm.

Product outfeed height: mm.

Infeed conveyor: Driven / Gravity

Outfeed conveyor: Driven / Gravity

Sensors included: Yes / No

Safety fencing: Yes / No

Safety fencing door: Yes / No

Lay-out: Send to sales@Qimarox.com

Environment conditions: _____

Remarks: _____

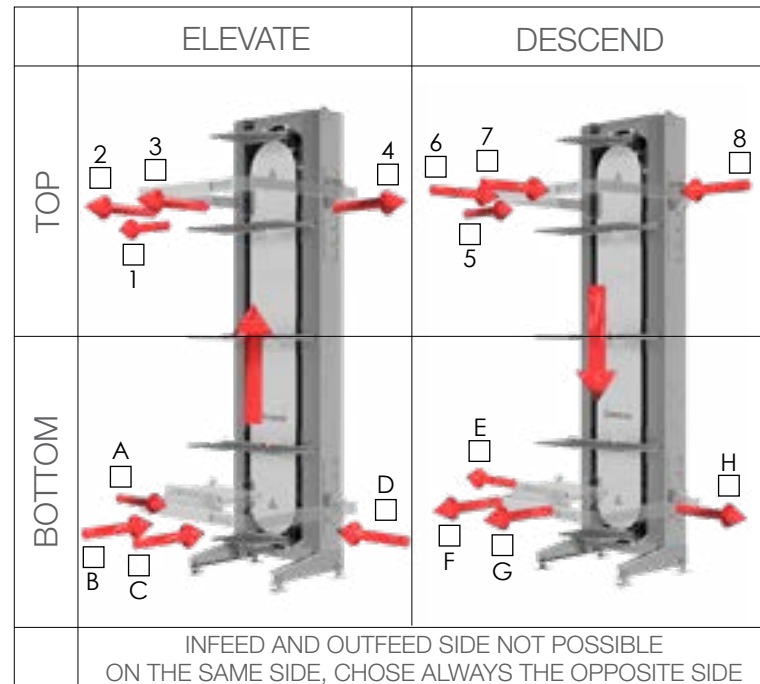

Suitable for

- Carton Trays • Bins • Tires • Books • Cardboard boxes • Shrink wrapped products • Soft parcels • Magazines
- Newspaper bundles • Frozen foods • Trays • Packaged bottles • Boxes • Bags • Totes

Disclaimer: This document is for informational and promotional purposes only. All orders are subject to the Qimarox terms and conditions and Qimarox's written confirmation. Copyright © 2023 Qimarox



Key Components for material handling:

- Vertical Conveyors • Palletizing Modules • Sorting & Buffering • Pallet Stackers • Safety Fencing

Advantages of the PRORUNNER® MK5-XL

- Line feed and cross feed
- No start-/stop movements
- Easy access to product carrier
- Possibility for in and out feed at multiple levels
- Number of carriers provide capacity
- Can be used as vertical sorter
- No critical product transitions
- Drive system is protected inside the column
- C-lift or Z-lift configurations possible
- Can be used as a cross transfer
- Admits product infeed from side and front
- Carrier always remains horizontal
- Low noise

Specifications Qimarox Prorunner MK5-XL		Basic model	Optional up to
Min. In / Outfeed	mm	810	810
Max. In / Outfeed	mm	2830	17300
Throughput	p/hour	400	1650
Product (Max. L x W) *	mm	900 x 410	900 x 610
Weight	kg	25	50

* Length side always parallel to lift column (=SSL side in/outfeed, LSL front in/outfeed).

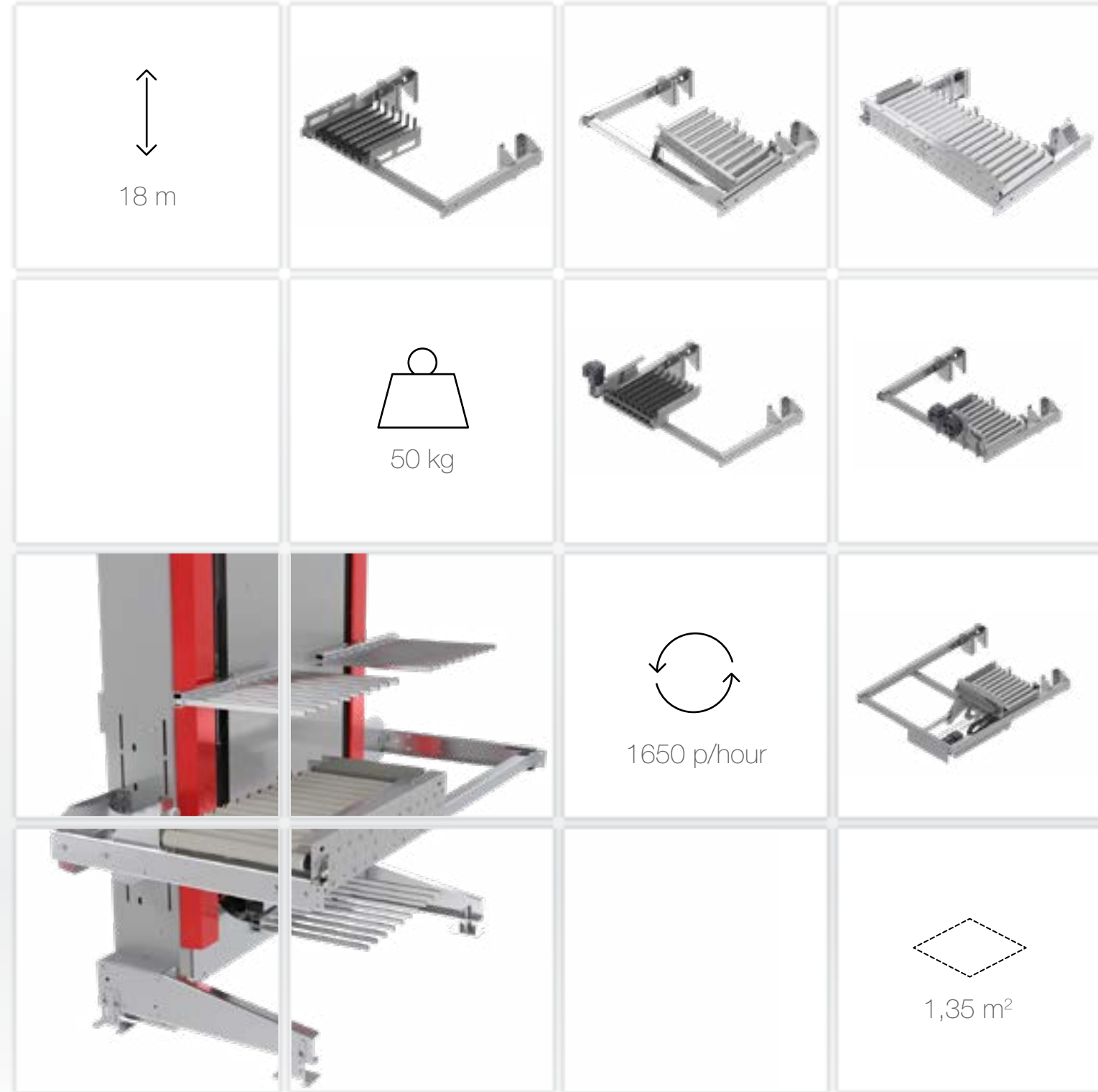

Key Components for material handling:

- Vertical Conveyors
- Palletizing Modules
- Sorting & Buffering
- Pallet Stackers
- Safety Fencing



Key Components for material handling:

- Vertical Conveyors
- Palletizing Modules
- Sorting & Buffering
- Pallet Stackers
- Safety Fencing